

**मोशन है, तो भरसा है**

**MOTION**  
18 YEARS OF LEGACY



# **SAMPLE QUESTION PAPERS**

**CBSE CLASS 12<sup>th</sup>**



a)  $ML^{-1}T^{-2}$

b)  $MLT^{-1}$

c)  $ML^2T^{-2}$

d)  $ML^2T^{-1}$

6. An electron is revolving around a proton in a circular orbit of diameter 0.1 nm. It produces a magnetic field of  $14 \text{ Wb/m}^2$  at the proton. What is angular speed of the electron? [1]

a)  $4.4 \times 10^{16} \text{ rads}^{-1}$

b)  $8.8 \times 10^{16} \text{ rads}^{-1}$

c)  $6.4 \times 10^{16} \text{ rads}^{-1}$

d)  $1.4 \times 10^{16} \text{ rads}^{-1}$

7. For MRI, a patient is slowly pushed in a time of 10 s within the coils of the magnet where magnetic field is  $B = 2.0 \text{ T}$ . If the patient's trunk is 0.8 m in circumference, the induced emf around the patient's trunk is [1]

a)  $10.18 \times 10^{-3} \text{ V}$

b)  $10.18 \times 10^{-2} \text{ V}$

c)  $1.51 \times 10^{-2} \text{ V}$

d)  $9.66 \times 10^2 \text{ V}$

8. Which of the following has its permeability less than that of free space? [1]

a) Copper

b) Nickel

c) Copper chloride

d) Aluminium

9. The wavefront of a distant source of unknown shape is approximately: [1]

a) plane

b) elliptical

c) cylindrical

d) spherical

10. An electron is moving round the nucleus of a hydrogen atom in a circular orbit of radius  $r$ . The Coulomb force  $\vec{F}$  between the two is: [1]

a)  $\kappa \frac{e^2}{r^3} \vec{r}$

b)  $-\kappa \frac{e^2}{r^3} \vec{r}$

c)  $-\kappa \frac{e^3}{r^3} \hat{r}$

d)  $\kappa \frac{e^2}{r^3} \hat{r}$

11. Two ideal diodes are connected to a battery as shown in the circuit. The current supplied by the battery is [1]

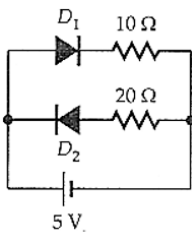

a) zero

b) 0.5 A

c) 0.75 A

d) 0.25 A

12. In the diagram, a prism of angle  $30^\circ$  is used. A ray PQ is incident as shown. An emergent ray RS emerges perpendicular to the second face. The angle of deviation is: [1]

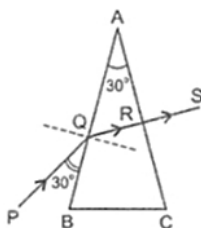

a)  $60^\circ$

b)  $0^\circ$

c)

d)

13. **Assertion (A):** In process of photoelectric emission, all emitted electrons do not have same kinetic energy. [1]  
**Reason (R):** If radiation falling on the photosensitive surface of metal consists of different wavelengths then energy acquired by electrons absorbing photons of different wavelengths shall be different.
- a) Both A and R are true and R is the correct explanation of A.      b) Both A and R are true but R is not the correct explanation of A.  
c) A is true but R is false.      d) A is false but R is true.
14. **Assertion:** If the distance between parallel plates a capacitor is halved and dielectric constant is made three times then the capacitance becomes six times. [1]  
**Reason:** (R) Capacitance of the capacitor does not depend upon the nature of the material of the plates of the capacitor.
- a) Assertion and reason both are correct statements and reason is correct explanation for assertion.      b) Assertion and reason both are correct statements but reason is not correct explanation for assertion.  
c) Assertion is correct statement but reason is wrong statement.      d) Assertion is wrong statement but reason is correct statement.
15. **Assertion (A):** Wavefront emitted by a point source of light in an isotropic medium is spherical. [1]  
**Reason (R):** Isotropic medium has same refractive index in all directions.
- a) Both A and R are true and R is the correct explanation of A.      b) Both A and R are true but R is not the correct explanation of A.  
c) A is true but R is false.      d) A is false but R is true.
16. **Assertion (A):** The quantity  $L/R$  possesses the dimension of time. [1]  
**Reason (R):** In order to reduce the rate of increase of current through a solenoid, we should increase the time constant.
- a) Both A and R are true and R is the correct explanation of A.      b) Both A and R are true but R is not the correct explanation of A.  
c) A is true but R is false.      d) A is false but R is true.

### Section B

17. In which situation is there a displacement current, but no conduction current? [2]
18. Magnetic force is always normal to the velocity of a charge and therefore does no work. An iron nail held near a magnet, when released, increases its kinetic energy as it moves to cling to the magnet. What agency is responsible for this increase in kinetic energy if not the magnetic field? [2]
19. In the following diagrams indicate which of the diodes are forward biased and which are reverse biased. [2]

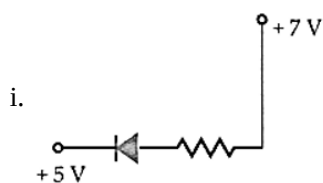

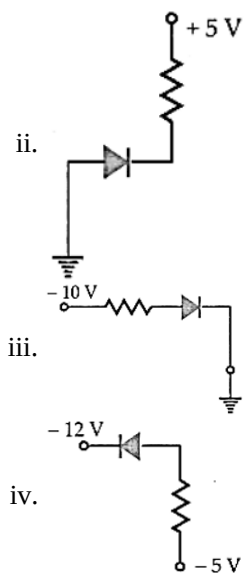

20. Suppose you are given a chance to repeat the alpha-particle scattering experiment using a thin sheet of solid hydrogen in place of the gold foil. (Hydrogen is a solid at temperatures below 14 K). What results do you expect? [2]
21. A circular coil of 25 turns and radius 6.0 cm, carrying a current of 10 A, is suspended vertically in a uniform magnetic field of magnitude 1.2 T. The field lines run horizontally in the plane of the coil. Calculate the force and the torque on the coil due to the magnetic field. In which direction should a balancing torque be applied to prevent the coil from turning? [2]

OR

Two identical circular loops, P and Q, each of radius  $r$  and carrying currents are kept in the parallel planes having a common axis passing through O. The direction of current in P is clockwise and in Q is anti-clockwise as seen from O which is equidistant from the loops P and Q. Find the magnitude of the net magnetic field at O.

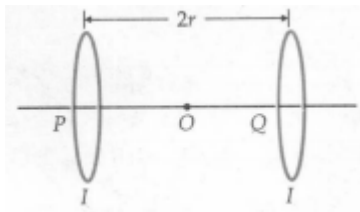

### Section C

22. A cell of emf  $E$  and internal resistance  $r$  is connected across a variable load resistor  $R$ . Draw the plots of the terminal voltage  $V$  versus (i) resistance  $R$  and (ii) current  $I$ . [3]  
It is found that when  $R = 4 \Omega$ , the current is 1A and when  $R$  is increased to  $9\Omega$ , the current reduces to 0.5 A. Find the values of the emf  $E$  and internal resistance  $r$ .
23. Explain with the help of a diagram, how a depletion layer and barrier potential are formed in a junction diode. [3]
24. Write Einstein's photoelectric equation in terms of the stopping potential and the threshold frequency for a given photosensitive material. Draw a plot showing the variation of stopping potential vs. the frequency of incident radiation. [3]
25. i. What characteristic property of nuclear force explains the constancy of binding energy per nucleon ( $BE/A$ ) in the range of mass number  $A$  lying  $30 < A < 170$ ? [3]  
ii. Show that the density of nucleus over a wide range of nuclei is constant and independent of mass number  $A$ .
26. a. Draw the energy level diagram for the line spectra representing Lyman series and Balmer series in the spectrum of hydrogen atom. [3]

- b. Using the Rydberg formula for the spectrum of hydrogen atom, calculate the largest and shortest wavelengths of the emission lines of the Balmer series in the spectrum of hydrogen atom. (Use the value of Rydberg constant  $R = 1.1 \times 10^7 \text{ m}^{-1}$ )
27. The absolute refractive index of air is 1.0003 and the wavelength of yellow light in a vacuum is  $6000 \text{ \AA}$ . Find the thickness of air column which will contain one more wavelength of yellow light than in the same thickness of vacuum. [3]
28. A horizontal straight wire 10 m long extending from east to west is falling with a speed of  $5.0 \text{ ms}^{-1}$ , at right angles to the horizontal component of the earth's magnetic field,  $0.30 \times 10^{-4} \text{ Wb m}^{-2}$ . [3]
- What is the instantaneous value of the emf induced in the wire?
  - What is the direction of the emf?
  - Which end of the wire is at the higher electrical potential?

OR

Define the term self-inductance. Write its SI unit. Give two factors on which self inductance of an air-core coil depends.

### Section D

29. **Read the text carefully and answer the questions:** [4]

Electrons oscillating in a circuit give rise to radiowaves. A transmitting antenna radiates most effectively the radiowaves of wavelength equal to the size of the antenna. The infrared waves incident on a substance set into oscillation all its electrons, atoms and molecules. This increases the internal energy and hence the temperature of the substance.

- (a) If  $v_g$ ,  $v_X$  and  $v_m$  are the speeds of gamma rays, X-rays and microwaves respectively in vacuum, then
- |                      |                      |
|----------------------|----------------------|
| a) $v_g > v_X > v_m$ | b) $v_g < v_X < v_m$ |
| c) $v_g > v_X > v_m$ | d) $v_g = v_X = v_m$ |
- (b) Which of the following will deflect in electric field?
- |                     |                   |
|---------------------|-------------------|
| a) ultraviolet rays | b) $\gamma$ -rays |
| c) X-rays           | d) cathode rays   |
- (c)  $\gamma$ -rays are detected by
- |                         |                       |
|-------------------------|-----------------------|
| a) point contact diodes | b) ionization chamber |
| c) thermopiles          | d) photocells         |

OR

We consider the radiation emitted by the human body. Which one of the following statements is true?

- The radiation emitted is in the infrared region.
  - The radiation is emitted only during the day.
  - The radiation is emitted during the summers and absorbed during the winters.
  - The radiation emitted lies in the ultraviolet region and hence it is not visible.
- |                 |                |
|-----------------|----------------|
| a) Option (iv)  | b) Option (ii) |
| c) Option (iii) | d) Option (i)  |
- (d) The frequency of electromagnetic wave, which best suited to observe a particle of radius  $3 \times 10^{-4} \text{ cm}$  is

the order of

a)  $10^{14}$  Hz

b)  $10^{12}$  Hz

c)  $10^{13}$  Hz

d)  $10^{15}$  Hz

30. Read the text carefully and answer the questions:

[4]

Coulomb's law states that the electrostatic force of attraction or repulsion acting between two stationary point charges is given by

$$F = \frac{1}{4\pi\epsilon_0} \frac{q_1 q_2}{r^2}$$



where  $F$  denotes the force between two charges  $q_1$  and  $q_2$  separated by a distance  $r$  in free space,  $\epsilon_0$  is a constant known as the permittivity of free space. Free space is a vacuum and may be taken to be air practically. If free space is replaced by a medium, then  $\epsilon_0$  is replaced by  $(\epsilon_0 k)$  or  $(\epsilon_0 \epsilon_r)$  where  $k$  is known as dielectric constant or relative permittivity.

(a) In coulomb's law,  $F = k \frac{q_1 q_2}{r^2}$ , then on which of the following factors does the proportionality constant  $k$  depends?

a) Nature of the medium between the two charges

b) Distance between the two charges

c) Electrostatic force acting between the two charges

d) Magnitude of the two charges

(b) Dimensional formula for the permittivity constant  $\epsilon_0$  of free space is

a)  $[M^{-1} L^3 T^2 A^2]$

b)  $[ML^{-3}T^4A^2]$

c)  $[M^{-1} L^{-3} T^4 A^2]$

d)  $[M L^{-3} T^4 A^{-2}]$

(c) The force of repulsion between two charges of 1 C each, kept 1m apart in vacuum is

a)  $\frac{1}{9 \times 10^9}$  N

b)  $\frac{1}{9 \times 10^{12}}$  N

c)  $9 \times 10^7$  N

d)  $9 \times 10^9$  N

(d) Two identical charges repel each other with a force equal to 10 mgwt when they are 0.6 m apart in air. ( $g = 10 \text{ m s}^{-2}$ ). The value of each charge is

a) 2 mC

b)  $2 \times 10^{-7}$  mC

c) 2  $\mu$ C

d) 2 nC

**OR**

Coulomb's law for the force between electric charges most closely resembles with

a) law of conservation of energy

b) Newton's 2<sup>nd</sup> law of motion

c) law of conservation of charge

d) Newton's law of gravitation

**Section E**

31. i. Draw a ray diagram showing the image formation by a compound microscope. Hence obtain the expression for total magnification when the image is formed at least distance of distinct vision. [5]

- ii. A compound microscope consists of an objective lens of focal length 2.0 cm and an eyepiece of focal length 6.0 cm. If they are separated by a distance of 24 cm, find the total magnification when the image is formed at infinity.

OR

Using Huygens' principle, draw a diagram to show propagation of a wavefront originating from a monochromatic point source. Explain briefly.

32. Two point charges  $-q$  and  $q$  are located at points  $(0, 0, -a)$  and  $(0, 0, a)$  respectively. [5]
- Find the electrostatic potential at  $(0, 0, z)$  and  $(x, y, 0)$ .
  - How much work is done in moving a small test charge from the point  $(5, 0, 0)$  to  $(-7, 0, 0)$  along the x-axis?
  - How would your answer change if the path of the test charge between the same points is not along the x-axis but along any other random path?
  - If the above point charges are now placed in the same positions in the uniform external electric field  $\vec{E}$ , what would be the potential energy of the charging system in its orientation of unstable equilibrium?

Justify your answer in each case.

OR

- Derive an expression for the potential energy of an electric dipole in a uniform electric field. Explain conditions for stable and unstable equilibrium.
  - Is the electrostatic potential necessarily zero at a point where the electric field is zero? Give an example to support your answer.
33. i. Describe, with the help of a suitable diagram, the working principle of a step-up transformer. Obtain the relation between input and output voltages in terms of the number of turns of primary and secondary windings and the currents in the input and output circuits. [5]
- ii. Given the input current 15 A and the input voltage of 100 V for a step-up transformer having 90% efficiency, find the output power and the voltage in the secondary if the output current is 3 A.

OR

A series LCR circuit is connected to an a.c. source having voltage  $V = V_m \sin \omega t$ . Derive the expression for the instantaneous current  $I$  and its phase relationship to the applied voltage. Obtain the condition for resonance to occur. Define power factor. State the conditions under which it is

- maximum and
- minimum.



# Solution

## Section A

1. (a) 0.5 eV

**Explanation:**  $E_g = \frac{hc}{\lambda} = \frac{1240 \text{ eVnm}}{2800 \text{ nm}} = 0.5 \text{ eV}$

2. (a) 10 W

**Explanation:**  $P = \frac{V^2}{R}$  i.e.,  $P \propto V^2$

or  $\frac{P_1}{P_2} = \frac{V_1^2}{V_2^2}$  or  $\frac{40}{P_2} = \frac{(200)^2}{(100)^2}$

or  $P_2 = 10 \text{ W}$

3. (a) 2f

**Explanation:** The focal length of each part will be 2f

- 4.

(d)  $\chi \propto T^{-1}$

**Explanation:**  $\chi \propto T^{-1}$

5. (a)  $\text{ML}^{-1}\text{T}^{-2}$

**Explanation:**  $[\frac{1}{2}\epsilon_0 E^2] = \text{energy density}$   
 $= \frac{\text{ML}^2 \text{T}^{-2}}{\text{I}^3} = [\text{ML}^{-1}\text{T}^{-2}]$

6. (a)  $4.4 \times 10^{16} \text{ rads}^{-1}$

**Explanation:** The revolving electron is similar to a loop carrying current. Field at the center of the loop of radius r is  $B = \frac{\mu_0 I}{2r}$ .

The current due to the revolving electron  $I = \frac{B(2r)}{\mu_0} = \frac{14 \times 0.1 \times 10^{-9}}{4\pi \times 10^{-7}} = \frac{7 \times 10^{-3}}{2\pi}$

The current can also be written as,  $I = \frac{e}{T}$

where, T is the time taken to complete one revolution.

Since  $T = \frac{2\pi}{\omega}$  where  $\omega$  is the angular speed of the electron,

$$I = \frac{e}{T} = \frac{e\omega}{2\pi}$$

$$\frac{e\omega}{2\pi} = \frac{7 \times 10^{-3}}{2\pi}$$

$$\omega = \frac{7 \times 10^{-3}}{e} = \frac{7 \times 10^{-3}}{1.6 \times 10^{-19}}$$

$$= 4.38 \times 10^{16} \approx 4.4 \times 10^{16} \text{ rad/s}$$

7. (a)  $10.18 \times 10^{-3} \text{ V}$

**Explanation:** Change in magnetic field in 10s = 2.0 T

As  $\epsilon = \frac{-d\phi}{dt} = -A \frac{dB}{dt}$  ( $\because \phi = BA$ )

Circumference of patient's trunk,

$$2\pi r = 0.8 \text{ m (given)}$$

$$\therefore r = \frac{0.8}{2\pi} \text{ m} = \frac{0.4}{\pi} \text{ m}$$

Area of cross-section,

$$A = \pi r^2 = \pi \left(\frac{0.4}{\pi}\right)^2 = \frac{0.16}{\pi} \text{ m}^2$$

$$\therefore |\epsilon| = \frac{0.16}{\pi} \times \frac{2}{10} \text{ V}$$

$$\approx 10.18 \times 10^{-3} \text{ V}$$

8. (a) Copper

**Explanation:** as Copper is diamagnetic substance.

9. (a) plane

**Explanation:** When the point source or linear source of light is a very large distance, a small portion of the spherical or cylindrical wavefront appears to be plane. Such a wavefront is plane wavefront.

10.

(b)  $-\kappa \frac{e^2}{r^3} \vec{r}$

**Explanation:** Charge on an electron = -e

Charge on nucleus of hydrogen = +e

$$\therefore \vec{F} = \kappa \frac{(-e) \times e}{r^2} \hat{r} = -\frac{\kappa e^2}{r^3} \vec{r}$$

Here  $\hat{r} = \frac{\vec{r}}{r}$  is unit vector along the line joining electron to the nucleus. The negative sign shows that the force is of attraction.

11.

(b) 0.5 A

**Explanation:** Diode  $D_1$  conducts as it is forward biased.

Diode  $D_2$  does not conduct as it is reverse biased.

$$\therefore I = \frac{5V}{10\Omega} = 0.5 A$$

12.

(c)  $30^\circ$

**Explanation:**

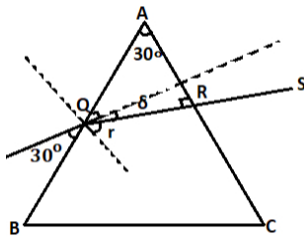

In  $\triangle AQR$

$$\angle A + \angle Q + \angle R = 180^\circ$$

$$30^\circ + 90^\circ - r + 90^\circ = 180^\circ$$

$$r = 30^\circ$$

$$\delta = 90^\circ - 30^\circ - r$$

$$\delta = 90^\circ - 30^\circ - 30^\circ$$

$$\delta = 30^\circ$$

so angle of deviation is 30 degree.



13.

(b) Both A and R are true but R is not the correct explanation of A.

**Explanation:** Both statements are true; but even if radiation of single wavelength is incident on a photosensitive surface, electrons of different kinetic energies will be emitted.

14.

(b) Assertion and reason both are correct statements but reason is not the correct explanation for the assertion.

**Explanation:** Assertion and reason both are correct statements but reason is not the correct explanation for the assertion.

15. (a) Both A and R are true and R is the correct explanation of A.

**Explanation:** If a medium has the same refractive index at every point in all directions, then the wavefront obtained from a point source in such a medium is spherical since waves travel in all directions with the same speed. Such a medium is known as an isotropic medium. So, the assertion and reason both are true and the reason explains the assertion properly.

16.

(c) A is true but R is false.

**Explanation:**  $I = \frac{\epsilon}{R} = \frac{L}{R} \frac{dI}{dt}$

$$\text{or } \left[ \frac{L}{R} \right] = I \cdot \frac{dt}{dI} = \frac{[I][T]}{[I]} = [T]$$

$\therefore$  A is true but R is false.

In order to reduce the rate of increase of current through the solenoid, we increase the time constant  $\left(\frac{L}{R}\right)$ . But L is given to be constant, so we use a high resistance R in series with it.

### Section B

17. During charging or discharging there is a displacement current but no conduction current between the plates of a capacitor.

18. We can think of the nail as so many charges in motion. In the bar's magnetic field, each charge in motion in the nail experiences a magnetic force that alters its velocity but not speed. The total energy of the system (the nail) cannot change, since magnetic force does no work. But because of changes in individual velocity directions, the velocity of the centre of mass can increase, obviously at the expense of the nail's internal energy. Magnetic field provides force, while internal energy of the nail provides the increase in internal energy of the nail as a whole.
19. i. Forward biased, because p-side is at higher potential (+7 V) than n-side (+5 V).  
 ii. Reverse biased, because the p-side is at lower potential (0V) than the n-side (+5 V).  
 iii. Reverse biased, because p-side is at lower potential (-10 V) than n-side (0 V).  
 iv. Forward biased, because p-side is at higher potential (-5 V) than n-side (-12 V).
20. Hydrogen nuclei (or protons) are much lighter than  $\alpha$ -particles. So  $\alpha$ -particles are not scattered by solid hydrogen. They pass through solid hydrogen almost undeflected from their paths.
21. Consider any element  $\vec{dl}$  of the wire. Force on this element is  $I \vec{dl} \times \vec{B}$ . For each element  $\vec{dl}$  there is another element  $-\vec{dl}$  on the current loop. Forces on each pair of such elements Cancel out. Hence net force on the coil in a uniform magnetic field is zero.

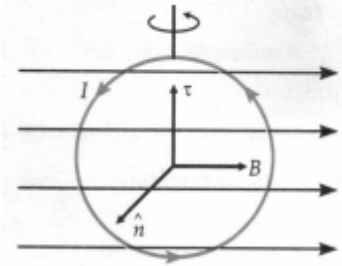

In Fig. n is a unit vector normal to the plane of the loop, directed outward. The angle between n and B is  $90^\circ$ . The magnitude of the torque acting on the loop is

$$\begin{aligned} \tau &= NIBA \sin \theta \\ &= 25 \times 10 \times 1.2 \times \pi(0.06)^2 \times \sin 90^\circ \\ &= 3.4 \text{ Nm} \end{aligned}$$

This torque acts in the vertically upward direction producing a turning effect in the direction of the curved arrow. To prevent the coil from turning, a balancing torque  $\tau' = \tau$  must be applied.

OR

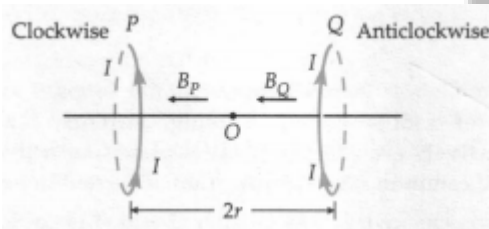

$$|\vec{B}_P| = |\vec{B}_Q| = \frac{\mu_0 I r^2}{2(r^2 + r^2)^{3/2}} = \frac{\mu_0 I}{4\sqrt{2}r}$$

The net magnetic field at O is

$$|\vec{B}| = |\vec{B}_P| + |\vec{B}_Q| = 2 \frac{\mu_0 I}{4\sqrt{2}r} = \frac{\mu_0 I}{2\sqrt{2}r}$$

### Section C

22. **Internal resistance** usually means the electrical **resistance** inside batteries and power supplies that can limit the potential difference that can be supplied to an external load

$$\therefore V = \left( \frac{E}{R+r} \right) R = \frac{E}{1+r/R}$$

$\Rightarrow$  with the increase of R, V increases

Graph between terminal voltage(V) and Current (I)

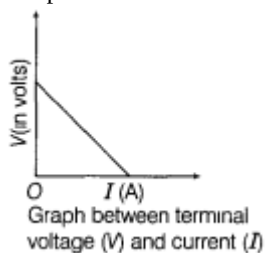

When  $R = 4\Omega$  and  $I = 1A$ .

We know that, terminal voltage,  $V = E - Ir$ .

$$\Rightarrow V = IR = 4 = E - Ir$$

$$\Rightarrow E - r = 4 \dots(i)$$

When  $R = 9\Omega$  and  $I = 0.5A$ , then

$$V = IR = 0.5 \times 9 = E - 0.5r$$

$$\Rightarrow E - 0.5r = 4.5 \dots(ii)$$

On solving Eqs. (i) and (ii), we get

$$r = 1\Omega \text{ and } E = 5V$$

So from the above calculation, it was found that the internal resistance of the cell is 1 ohm and emf is 5 volt.

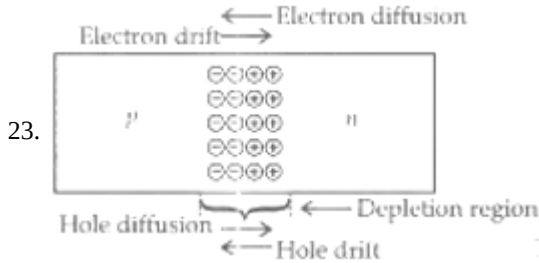

Due to the diffusion of electrons and holes, from their majority to minority zone, a layer of positive and negative space charge region on either side on the junction is formed. This is called the depletion region. The loss of electrons, from the n-region and the gain of electrons by the p-region, cause a difference of potential across the junction formed. This tends to prevent the further movement of charge carriers across the junction and is, therefore, termed as barrier potential.

24. Einstein's photoelectric equation,

K.E. of photo electron = incident energy of photons - Work function

$$\text{or K.E.} = h\nu - W_0$$

$$\text{or K.E.} = h\nu - h\nu_0$$

where  $\nu_0$  is called threshold frequency.

- i. **Threshold Frequency:** For a given metal, there exists a certain minimum frequency of the incident radiation below which no emission of photo electrons takes place. This frequency is called threshold frequency.
- ii. **Stopping Potential:** It is that minimum negative potential given to anode in a photocell for which the photoelectric current becomes zero. It is denoted by  $V_0$ . It is independent of the intensity of the incident light.

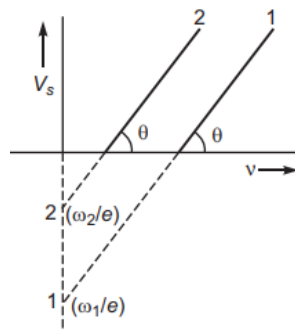

25. i. The characteristic property of nuclear force that explains the constancy of binding energy per nucleon is the saturation or short range nature of nuclear forces.

In heavy nuclei, nuclear size  $>$  a range of nuclear force.

ii. Using the formula for the radius of the nucleon, we have

$$R = R_0 A^{1/3}$$

Let,  $m$  be the mass of a nucleon,

therefore,

$$\text{density, } \rho = \frac{mA}{\frac{4}{3}\pi(R_0 A^{1/3})^3} = \frac{mA}{\frac{4}{3}\pi R_0^3 A} = \frac{m}{\frac{4}{3}\pi R_0^3}$$

Thus, we can see that density is constant and independent of mass number  $A$ .

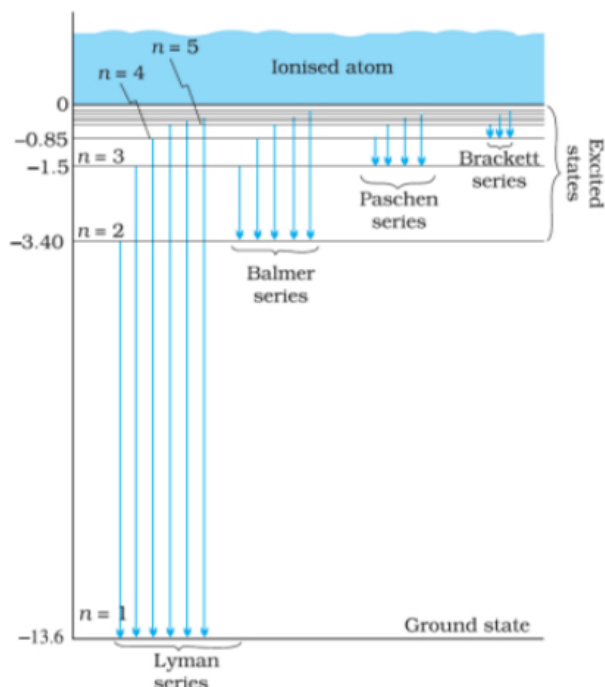

26. a.

$$\begin{aligned}
 \text{b. } \frac{1}{\lambda_{\text{longest}}} &= R \left\{ \frac{1}{n_f^2} - \frac{1}{n_c^2} \right\} = R \frac{5}{36} \\
 \lambda_{\text{max}} &= \frac{36}{5R} \\
 &= \frac{36}{5 \times 1.1 \times 10^7} \text{ m} \\
 &= 6.5 \times 10^{-7} \text{ m} \\
 \frac{1}{\lambda_{\text{smallest}}} &= R \left\{ \frac{1}{2^2} - \frac{1}{\infty^2} \right\} \\
 &= \frac{R}{4} \\
 \lambda_{\text{mm}} &= \frac{4}{R} = \frac{4}{1.1 \times 10^7} \text{ m} \\
 &= 3.6 \times 10^{-7} \text{ m}
 \end{aligned}$$

27. Wavelength of yellow light in vacuum,

$$\lambda = 6000 \text{ \AA}$$

Wavelength of yellow light in air

$$\lambda' = \frac{\lambda}{\mu} = \frac{6000}{1.0003} \text{ \AA}$$

Let a thickness  $t$  of vacuum contain  $n$  waves and the same thickness  $t$  of air contain  $n + 1$  waves.

$$\text{Then } n = \frac{t}{\lambda} = \frac{t}{6000 \text{ \AA}}$$

$$\text{and } n + 1 = \frac{t}{\lambda'} = \frac{1.0003t}{6000 \text{ \AA}}$$

From the above two equations, we get

$$\frac{t}{6000 \text{ \AA}} + 1 = \frac{1.0003t}{6000 \text{ \AA}} \text{ or } t + 6000 \text{ \AA} = 1.0003 t$$

$$\text{or } t = \frac{6000}{0.0003} = 2 \times 10^7 \text{ \AA} = 2 \text{ mm.}$$

28. Length of the wire,  $l = 10 \text{ m}$

Falling speed of the wire,  $v = 5.0 \text{ m/s}$

Magnetic field strength,  $B = 0.3 \times 10^{-4} \text{ wb m}^{-2}$

a. the instantaneous value of Emf induced in the wire,

$$e = Blv$$

$$= 0.3 \times 10^{-4} \times 5 \times 10$$

$$= 1.5 \times 10^{-3} \text{ V}$$

b. Using Fleming's right-hand rule, it can be inferred that the direction of the induced emf is from West to East.

c. The eastern end of the wire is at a higher potential.

OR

Self-inductance of a coil is equal to the total magnetic flux linked with the coil, when unit current passes through it.  
SI unit of self-inductance is Henry (H).

- i. number of turns of the coil
- ii. area of cross section and length (geometry)

### Section D

#### 29. Read the text carefully and answer the questions:

Electrons oscillating in a circuit give rise to radiowaves. A transmitting antenna radiates most effectively the radiowaves of wavelength equal to the size of the antenna. The infrared waves incident on a substance set into oscillation all its electrons, atoms and molecules. This increases the internal energy and hence the temperature of the substance.

- (i) **(d)**  $v_g = v_X = v_m$   
**Explanation:** All electromagnetic waves travel in vacuum with the same speed.
- (ii) **(d)** cathode rays  
**Explanation:** Cathode rays (beam of electrons) get deflected in an electric field.
- (iii) **(b)** ionization chamber  
**Explanation:**  $\gamma$ -rays are detected by ionization chamber.

OR

- (d)** Option (i)  
**Explanation:** Everybody at a temperature  $T > 0$  K emits radiation in the infrared region.

- (iv) **(a)**  $10^{14}$  Hz  
**Explanation:** Size of particle =  $\lambda = \frac{c}{\nu}$   
 $\nu = \frac{c}{\lambda} = \frac{3 \times 10^{10} \text{ cm s}^{-1}}{3 \times 10^{-4} \text{ cm}} = 3 \times 10^{14} \text{ Hz}$

#### 30. Read the text carefully and answer the questions:

Coulomb's law states that the electrostatic force of attraction or repulsion acting between two stationary point charges is given by

$$F = \frac{1}{4\pi\epsilon_0} \frac{q_1 q_2}{r^2}$$



where  $F$  denotes the force between two charges  $q_1$  and  $q_2$  separated by a distance  $r$  in free space,  $\epsilon_0$  is a constant known as the permittivity of free space. Free space is a vacuum and may be taken to be air practically. If free space is replaced by a medium, then  $\epsilon_0$  is replaced by  $(\epsilon_0 k)$  or  $(\epsilon_0 \epsilon_r)$  where  $k$  is known as dielectric constant or relative permittivity.

- (i) **(a)** Nature of the medium between the two charges  
**Explanation:** The proportionality constant  $k$  depends on the nature of the medium between the two charges.

- (ii) **(b)**  $[ML^{-3}T^4A^2]$   
**Explanation:**  $[ML^{-3}T^4A^2]$

- (iii) **(d)**  $9 \times 10^9$  N  
**Explanation:**  $9 \times 10^9$  N

- (iv) **(c)**  $2 \mu\text{C}$   
**Explanation:**  $F = \frac{1}{4\pi\epsilon_0} \frac{q_1 q_2}{d^2}$   
 $\therefore (10 \times 10^{-3}) \times 10 = \frac{(9 \times 10^9) \times q^2}{(0.6)^2}$   
or  $q^2 = \frac{10^{-1} \times 0.36}{9 \times 10^9} = 4 \times 10^{-12}$   
or  $q = 2 \times 10^{-6} \text{ C} = 2 \mu\text{C}$

OR

- (d)** Newton's law of gravitation  
**Explanation:** Newton's law of gravitation

### Section E

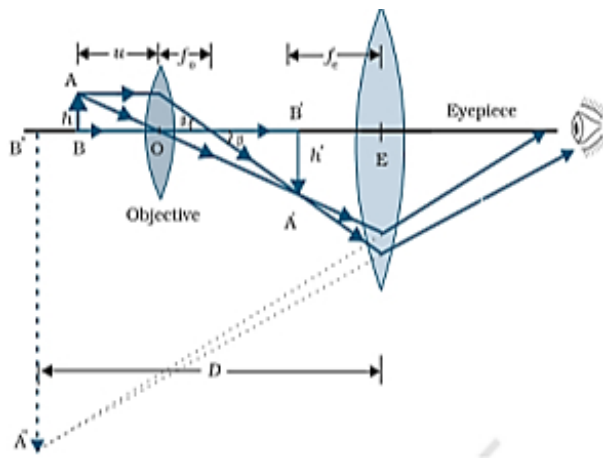

31. i.

Magnification due to objective

$$m_0 = \frac{h'}{h} = \frac{L}{f_0} \left( \because \tan \beta = \frac{h}{f_0} = \frac{h}{L} \right)$$

Magnification due to eye piece when final image is formed at the near point

$$m_e = 1 + \frac{D}{f_e}$$

Total magnification

$$m = m_0 m_e$$

$$m = \frac{L}{f_0} \left( 1 + \frac{D}{f_e} \right)$$

ii.  $m = \frac{LD}{f_0 f_e}$

$$m = \frac{24 \times 25}{2 \times 6} = \frac{600}{12} = 50$$

Hence, the total magnification when the image is formed at infinity is 50.

OR

**Propagation of Wavefront from a Point Source:**

This principle is useful for determining the position of a given wavefront at any time in the future if we know its present position. The principle may be stated in three parts as follows:

- i. Every point on a given wavefront may be regarded as a source of new disturbance.
- ii. The new disturbances from each point spread out in all directions with the velocity of light and are called the secondary wavelets.
- iii. The surface of tangency to the secondary wavelets in forward direction at any instant gives the new position of the wavefront at that time.

Let us illustrate this principle by the following example:

Let AB shown in the fig. be the section of a wavefront in a homogeneous isotropic medium at  $t = 0$ . We have to find the position of the wavefront at time  $t$  using Huygens' principle. Let  $v$  be the velocity of light in the given medium.

- (a) Take the number of points 1, 2, 3, ... on the wavefront AB. These points are the sources of secondary wavelets.
- (b) At time  $t$  the radius of these secondary wavelets is  $vt$ . Taking each point as centre, draw circles of radius  $vt$ .
- (c) Draw a tangent  $A_1 B_1$  common to all these circles in the forward direction. This gives the position of new wavefront at the required time  $t$ .

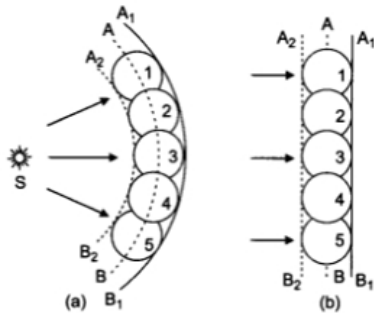

The Huygens' construction gives a backward wavefront also shown by dotted line  $A_2 B_2$  which is contrary to observation. The difficulty is removed by assuming that the intensity of the spherical wavelets is not uniform in all directions; but varies continuously from a maximum in the forward direction to a minimum of zero in the backward direction.

The directions which are normal to the wavefront are called rays, i.e., a ray is the direction in which the disturbance is propagated.

32. We have, for a point charge,  $V = \frac{1}{4\pi\epsilon_0} \cdot \frac{q}{r}$

(i). At point (0, 0, z) :

Potential due to the charge (+q)

$$V_+ = \frac{1}{4\pi\epsilon_0} \cdot \frac{q}{(z-a)}$$

Potential due to the charge (~q)

$$V_- = \frac{1}{4\pi\epsilon_0} \cdot \frac{(-q)}{(z+a)}$$

Total Potential at (0, 0, z)  $V = V_+ + V_-$

$$= \frac{q}{4\pi\epsilon_0} \left[ \frac{-1}{z+a} + \frac{1}{z-a} \right]$$

$$= \frac{2qa}{4\pi\epsilon_0(z^2-a^2)}$$

At point (x, y, 0)

Potential due to the charge + q

$$V_+ = \frac{1}{4\pi\epsilon_0} \cdot \frac{q}{\sqrt{x^2+y^2+a^2}}$$

Potential due to the charge (- q)

$$V_- = \frac{1}{4\pi\epsilon_0} \cdot \frac{-q}{\sqrt{x^2+y^2+a^2}}$$

Total potential at (x, y, 0)

$$= \frac{q}{4\pi\epsilon_0} \left( \frac{1}{\sqrt{x^2+y^2+a^2}} - \frac{1}{\sqrt{x^2+y^2+a^2}} \right) = 0 \text{ Hence total potential due to them at the given point will be zero.}$$

(ii). Work done =  $q[V_1 - V_2]$

$$V_1 = 0 \text{ and } V_2 = 0$$

$$\therefore \text{Work done} = 0$$

Where  $V_1$  and  $V_2$  are the total potential due to dipole at point (5, 0, 0) and (-7, 0, 0)

(iii). There would be no change This is because the electrostatic field is a conservative field.

(Alternatively: The work done, in moving a test charge between two given points is independent of the path taken ,it depends only on initial and final value.)

(iv). The two given charges make an electric dipole of dipole moment  $\vec{p} = q \cdot 2\vec{a}$

P.E. in the position of unstable equilibrium(  $\theta=180^\circ$ )(where  $\vec{p}$  and  $\vec{E}$  are antiparallel to each other) =  $pE\cos 180^\circ$

$$\cos 180^\circ = -1$$

Thus potential energy is =  $+ pE = 2aqE$

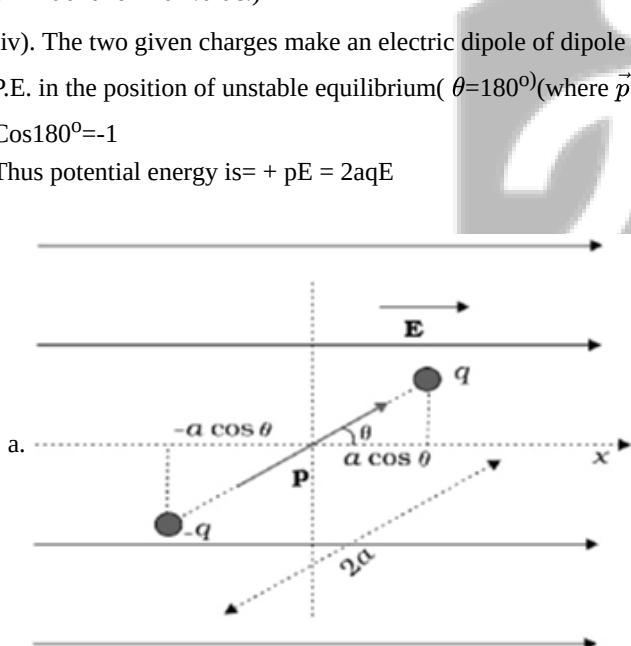

OR

Since torque acting on dipole

$$\vec{\tau} = \vec{p} \times \vec{E}$$

$$\tau = pE \sin \theta \cdot \hat{n}$$

$$\text{work done } d\omega = \tau \cdot d\theta$$

$$= pE \sin \theta d\theta$$

$$w = \int_{\theta_1}^{\theta_2} d\omega = pE \int_{\theta_1}^{\theta_2} \sin \theta d\theta$$

$$w = pE [-\cos \theta]_{\theta_1}^{\theta_2}$$

$$= pE [\cos \theta_1 - \cos \theta_2]$$



if  $\theta_1 = 0, \theta_2 = \theta$

$$w = pE (1 - \cos\theta)$$

Conditions-

For stable equilibrium - When electric dipole is parallel to electric field.

For unstable equilibrium - Anti Parallel to electric field.

b. No.

Inside equipotential surface

33. i.

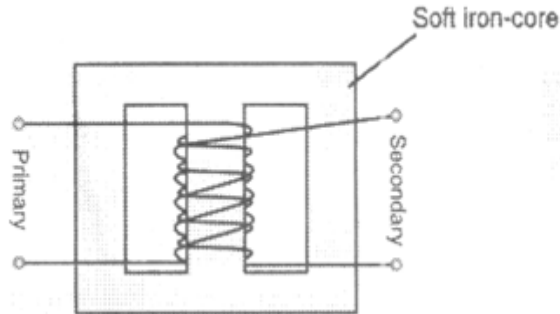

Working principle:

Step-down transformer is made up of two or more coil wound on the iron core of the transformer. It works on the principle of magnetic induction between the coils. Whenever current in one coil changes an emf gets induced in the neighboring coil (Principle of mutual induction)

Voltage across secondary

$$V_s = e_s = -N_s \frac{d\phi}{dt}$$

Voltage across primary

$$V_p = e_p = -N_p \frac{d\phi}{dt}$$

$$\frac{V_s}{V_p} = \frac{N_s}{N_p} \text{ (here, } N_s > N_p \text{)}$$

In an ideal transformer

Power Input - Power output

$$I_p V_p = I_s V_s$$

$$\therefore \frac{V_s}{V_p} = \frac{N_s}{N_p} = \frac{I_p}{I_s}$$

ii.

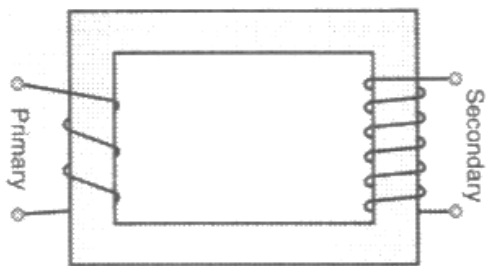

$$\text{Input power, } P_i = I_i \times V_i = 15 \times 100 = 1500 \text{ W}$$

$$\text{Power output, } P_o = P_i \times \frac{90}{100} = 1350 \text{ W}$$

$$\Rightarrow I_o V = 1350 \text{ W}$$

$$\text{Output voltage, } V_o = \frac{1350}{3} \text{ V} = 450 \text{ V}$$

OR

Suppose resistance R, inductance L and capacitance C are connected in series and an alternating source of voltage  $V = V_0 \sin \omega t$  is applied across it. (fig. a) On account of being in series, the current (i) flowing through all of them is the same.

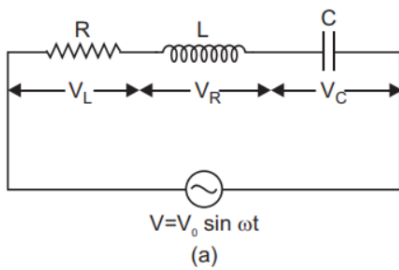

Suppose the voltage across resistance R is  $V_R$ , voltage across inductance L is  $V_L$  and voltage across capacitance C is  $V_C$ . The voltage  $V_R$  and current  $i$  are in the same phase, the voltage  $V_L$  will lead the current by angle  $90^\circ$  while the voltage  $V_C$  will lag behind the current by angle  $90^\circ$ . Clearly  $V_C$  and  $V_L$  are in opposite directions, therefore their resultant potential difference =  $V_C - V_L$  (if  $V_C > V_L$ ).

Thus  $V_R$  and  $(V_C - V_L)$  are mutually perpendicular and the phase difference between them is  $90^\circ$ . As applied voltage across the circuit is  $V$ , the resultant of  $V_R$  and  $(V_C - V_L)$  will also be  $V$ .

From fig.

$$V^2 = V_R^2 + (V_C - V_L)^2 \Rightarrow V = \sqrt{V_R^2 + (V_C - V_L)^2} \dots\dots(i)$$

But  $V_R = Ri$ ,  $V_C = X_C i$  and  $V_L = X_L i \dots\dots(ii)$

capacitance reactance and  $X_L = \omega L =$  inductive reactance

$$\therefore V = \sqrt{(Ri)^2 + (X_C i - X_L i)^2}$$

$$\therefore \text{Impedance of circuit, } Z = \frac{V}{i} = \sqrt{R^2 + (X_C - X_L)^2}$$

$$\text{i.e., } Z = \sqrt{R^2 + (X_C - X_L)^2} = \sqrt{R^2 + \left(\frac{1}{\omega C} - \omega L\right)^2}$$

Instantaneous current

$$I = \frac{V_0 \sin(\omega t + \phi)}{\sqrt{R^2 + \left(\frac{1}{\omega C} - \omega L\right)^2}}$$

Condition for resonance to occur in series LCR ac circuit:

For resonance, the current produced in the circuit and emf applied must always be in the same phase.

Phase difference ( $\phi$ ) in series LCR circuit is given by

$$\tan \phi = \frac{X_C - X_L}{R}$$

$$\text{For resonance } \phi = 0 \Rightarrow X_C - X_L = 0$$

$$\text{or } X_C = X_L$$

If  $\omega_r$  is resonant frequency, then

$$\text{and } X_L = \omega_r L$$

$$\therefore \frac{1}{\omega_r C} = \omega_r L \Rightarrow \omega_r = \frac{1}{\sqrt{LC}}$$

Power factor is the cosine of phase angle  $\phi$ , i.e.,  $\cos \phi = R/Z$ .

For maximum power  $\cos \phi = 1$  or  $Z = R$

i.e., circuit is purely resistive.

For minimum power  $\cos \phi = 0$  or  $R = 0$

i.e., circuit should be free from ohmic resistance.

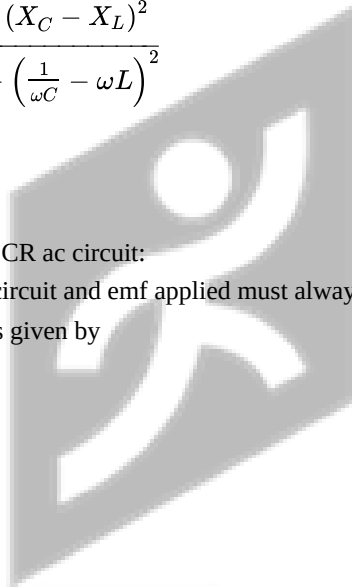

# YOUR SUCCESS STARTS HERE



**ADMISSION OPEN (JEE/NEET)**

**DROPPER/ACHIEVER BATCH**  
**26<sup>th</sup> March 2025**

**MOTION**

**PRE-ENGINEERING**  
JEE (Main+Advanced)

**PRE-MEDICAL**  
NEET

**Olympiads (Class 6th to 10th)**  
Boards

CORPORATE OFFICE

"Motion Education" 394, Rajeev Gandhi Nagar, Kota 324005 (Raj.)

Toll Free : 18002121799 | [www.motion.ac.in](http://www.motion.ac.in) | Mail : [info@motion.ac.in](mailto:info@motion.ac.in)

**MOTION  
LEARNING APP**



Scan Code for Demo Class