

# NEET UG 2026

## 100 Most Expected NCERT Questions With Answers

### Physics

**QUESTION 1:** The ratio of distances travelled by a freely falling body during the 1<sup>st</sup> 2<sup>nd</sup> 3<sup>rd</sup> and 4<sup>th</sup> second is:

- (1) 1 : 1 : 1 : 1
- (2) 1 : 2 : 3 : 4
- (3) 1 : 4 : 9 : 16
- (4) 1 : 3 : 5 : 7

**Correct Answer:** (4)

**Explanation:** Distance in  $n^{\text{th}}$  second  $S_n = \frac{g}{2}(2n - 1)$  so ratio 1 : 3 : 5 : 7.

**QUESTION 2:** If a soap bubble expands its radius increases. The pressure inside the bubble:

- (1) Becomes equal to atmospheric pressure
- (2) Decreases
- (3) Increases
- (4) Remains same

**Correct Answer:** (2)

**Explanation:** Excess pressure  $P = \frac{4T}{r}$  decreases as radius increases.

**QUESTION 3:** With increase in temperature the electrical resistance:

- (1) Decreases for conductors increases for semiconductors
- (2) Increases for both
- (3) Decreases for both
- (4) Increases for conductors decreases for semiconductors

**Correct Answer:** (4)

**Explanation:** Metals have positive temperature coefficient semiconductors negative.

**QUESTION 4:** Plane angle and solid angle:

- (1) Have both units and dimensions
- (2) Have units but no dimensions
- (3) Have dimensions but no units
- (4) Have neither units nor dimensions

**Correct Answer:** (2)

**Explanation:** Radian steradian dimensionless but treated as units.

**QUESTION 5:** In a half wave rectifier if input frequency is  $60Hz$  output frequency is:

- (1)  $120Hz$
- (2)  $0Hz$
- (3)  $30Hz$
- (4)  $60Hz$

**Correct Answer:** (4)

**Explanation:** Half wave rectifier gives one pulse per cycle.

**QUESTION 6:** Angle between electric field lines and equipotential surface is:

- (1)  $0^\circ$
- (2)  $45^\circ$
- (3)  $90^\circ$
- (4)  $180^\circ$

**Correct Answer:** (3)

**Explanation:** Electric field always perpendicular to equipotential surface.

**QUESTION 7:** A shell initially at rest explodes into three fragments of masses in the ratio  $2 : 2 : 1$ . The two heavier fragments move perpendicular to each other with equal speed  $v$ .

The speed of the lighter fragment is:

- (1)  $v$
- (2)  $\sqrt{2}v$
- (3)  $2\sqrt{2}v$
- (4)  $4v$

**Correct Answer:** (3)

**Explanation:** Resultant momentum =  $2mv\sqrt{2}$  hence lighter fragment speed  $2\sqrt{2}v$ .

**QUESTION 8:** A spherical ball is dropped in a long column of viscous liquid. The speed vs time graph is:

- (1) Decreasing

- (2) Increasing then constant
- (3) Constant
- (4) Linear increase

**Correct Answer:** (2)

**Explanation:** Velocity increases until terminal velocity then becomes constant.

**QUESTION 9:** A long solenoid having 1000 turns per metre carries a current of 1A. Magnetic field at centre is:

- (1)  $6.28 \times 10^{-4}T$
- (2)  $6.28 \times 10^{-2}T$
- (3)  $12.56 \times 10^{-4}T$
- (4)  $12.56 \times 10^{-2}T$

**Correct Answer:** (3)

**Explanation:**  $B = \mu_0 n I = 4\pi \times 10^{-7} \times 1000 \times 1 = 12.56 \times 10^{-4}T$ .

**QUESTION 10:** The ratio of radius of gyration of a uniform disc about an axis through its centre perpendicular to plane and about a tangent in plane is:

- (1)  $1 : \sqrt{2}$
- (2)  $\sqrt{2} : 1$
- (3)  $2 : 1$
- (4)  $1 : 2$

**Correct Answer:** (2)

**Explanation:**  $k_{center} = \frac{R}{\sqrt{2}}$  and  $k_{tangent} = R$  ratio  $\sqrt{2} : 1$ .

**QUESTION 11:** If a nucleus of mass number 189 splits into two nuclei of mass numbers 125 and 64 ratio of radii is:

- (1) 25 : 16
- (2) 5 : 4
- (3) 4 : 5
- (4) 1 : 1

**Correct Answer:** (2)

**Explanation:** Nuclear radius  $R = R_0 A^{1/3}$  so ratio  $125^{1/3} : 64^{1/3} = 5 : 4$ .

**QUESTION 12:** Two conducting spheres have equal charge. Potential is:

- (1) Same for both
- (2) Larger sphere higher
- (3) Smaller sphere higher
- (4) Depends on material

**Correct Answer:** (3)

**Explanation:** Potential  $V = \frac{kQ}{R}$  smaller radius gives larger potential.

**QUESTION 13:** Two simple pendulums have lengths  $121\text{cm}$  and  $100\text{cm}$ . If they start oscillating together the minimum number of oscillations completed by shorter pendulum when they again come in phase is:

- (1) 8
- (2) 11
- (3) 9
- (4) 10

**Correct Answer:** (2)

**Explanation:**  $T \propto \sqrt{L}$  so  $T_1 : T_2 = 11 : 10$  shorter completes 11 oscillations.

**QUESTION 14:** Number of moles in  $4.5\text{kg}$  of water is:

- (1) 25
- (2) 250
- (3) 450
- (4) 18

**Correct Answer:** (2)

**Explanation:**  $n = \frac{4500}{18} = 250$  moles.

**QUESTION 15:** Kirchoff junction rule is based on conservation of:

- (1) Energy
- (2) Charge
- (3) Momentum
- (4) Mass

**Correct Answer:** (2)

**Explanation:** Sum of currents entering equals leaving node.

**QUESTION 16:** Arrange in decreasing order of wavelength: AM radio waves Microwaves Infrared rays X rays

- (1) AM radio waves > Microwaves > Infrared > X rays
- (2) X rays > Infrared > Microwaves > AM radio waves
- (3) Microwaves > AM radio waves > Infrared > X rays
- (4) Infrared > Microwaves > AM radio waves > X rays

**Correct Answer:** (1)

**Explanation:** EM spectrum wavelength decreases radio to X rays.

**QUESTION 17:** Velocity of electromagnetic wave in medium is:

- (1)  $v = \frac{c}{\sqrt{\epsilon_r \mu_r}}$
- (2)  $v = c$
- (3)  $v = \sqrt{\frac{\mu_r}{\epsilon_r}}$
- (4)  $v = \sqrt{\frac{\epsilon_r}{\mu_r}}$

**Correct Answer:** (1)

**Explanation:** Wave speed depends on permittivity and permeability.

**QUESTION 18:** A biconvex lens has radii  $20\text{cm}$  each refractive index 1.5. Power is:

- (1)  $+2D$
- (2)  $+5D$
- (3)  $+10D$
- (4)  $+20D$

**Correct Answer:** (2)

**Explanation:** Lens maker gives  $f = 20\text{cm} = 0.2\text{m}$  so  $P = 5D$ .

**QUESTION 19:** Peak voltage of AC source is:

- (1)  $\frac{V_{rms}}{\sqrt{2}}$
- (2)  $V_{rms}$
- (3)  $\sqrt{2}V_{rms}$
- (4)  $2V_{rms}$

**Correct Answer:** (3)

**Explanation:**  $V_0 = \sqrt{2}V_{rms}$ .

**QUESTION 20:** A force  $3\text{N}$  acts on mass  $60\text{g}$ . Acceleration is:

- (1)  $5\text{m/s}^2$
- (2)  $50\text{m/s}^2$
- (3)  $0.05\text{m/s}^2$
- (4)  $500\text{m/s}^2$

**Correct Answer:** (2)

**Explanation:**  $a = \frac{F}{m} = \frac{3}{0.06} = 50\text{m/s}^2$ .

**QUESTION 21:** The correct order of magnetic susceptibility is:

- (1)  $\chi_{ferromagnetic} \gg \chi_{paramagnetic} > 0 > \chi_{diamagnetic}$
- (2)  $\chi_{paramagnetic} \gg \chi_{ferromagnetic} > 0 > \chi_{diamagnetic}$
- (3)  $\chi_{diamagnetic} > \chi_{paramagnetic} > \chi_{ferromagnetic}$
- (4)  $\chi_{ferromagnetic} < \chi_{paramagnetic} < \chi_{diamagnetic}$

**Correct Answer:** (1)

**Explanation:** Diamagnetic small negative paramagnetic small positive ferromagnetic very large positive susceptibility.

**QUESTION 22:** At Brewster angle  $i_B$  the reflected light is:

- (1) Completely unpolarised
- (2) Completely plane polarised
- (3) Circularly polarised
- (4) Elliptically polarised

**Correct Answer:** (2)

**Explanation:** At Brewster angle reflected ray is fully plane polarised and  $\tan i_B = \frac{n_2}{n_1}$ .

**QUESTION 23:** The graph between de Broglie wavelength  $\lambda$  and momentum  $p$  is:

- (1) Straight line
- (2) Hyperbola
- (3) Parabola
- (4) Circle

**Correct Answer:** (2)

**Explanation:**  $\lambda = \frac{h}{p}$  inverse relation hence rectangular hyperbola.

**QUESTION 24:** On a  $PV$  diagram an adiabatic curve compared to isothermal curve is:

- (1) Less steep
- (2) Same
- (3) More steep
- (4) Straight line

**Correct Answer:** (3)

**Explanation:** For adiabatic  $PV^\gamma = \text{constant}$  with  $\gamma > 1$  gives steeper curve.

**QUESTION 25:** The advantage of potentiometer over voltmeter is that it:

- (1) Measures current directly
- (2) Draws no current at balance condition
- (3) Works only for AC
- (4) Has negligible resistance

**Correct Answer:** (2)

**Explanation:** At null point no current flows so accurate EMF measurement.

**QUESTION 26:** Net magnetic flux through any closed surface is:

- (1) Positive
- (2) Negative
- (3) Zero
- (4) Infinite

**Correct Answer:** (3)

**Explanation:** Gauss law for magnetism  $\oint \vec{B} \cdot d\vec{S} = 0$ .

**QUESTION 27:** Direction of angular acceleration vector is:

- (1) Tangential
- (2) Radial inward
- (3) Along axis of rotation
- (4) Opposite angular velocity

**Correct Answer:** (3)

**Explanation:** Angular acceleration is axial vector given by right hand rule.

**QUESTION 28:** Ratio of energies of hydrogen atom in second and third excited states is:

- (1) 9 : 4
- (2) 4 : 9
- (3) 1 : 4
- (4) 4 : 1

**Correct Answer:** (1)

**Explanation:**  $E_n = -\frac{13.6}{n^2}$  for  $n = 3$  and  $n = 4$  gives  $E_3 : E_4 = 9 : 4$ .

**QUESTION 29:** In the following  $p$ - $n$  junction diode circuits shown the potential drop across identical junctions is equal in:

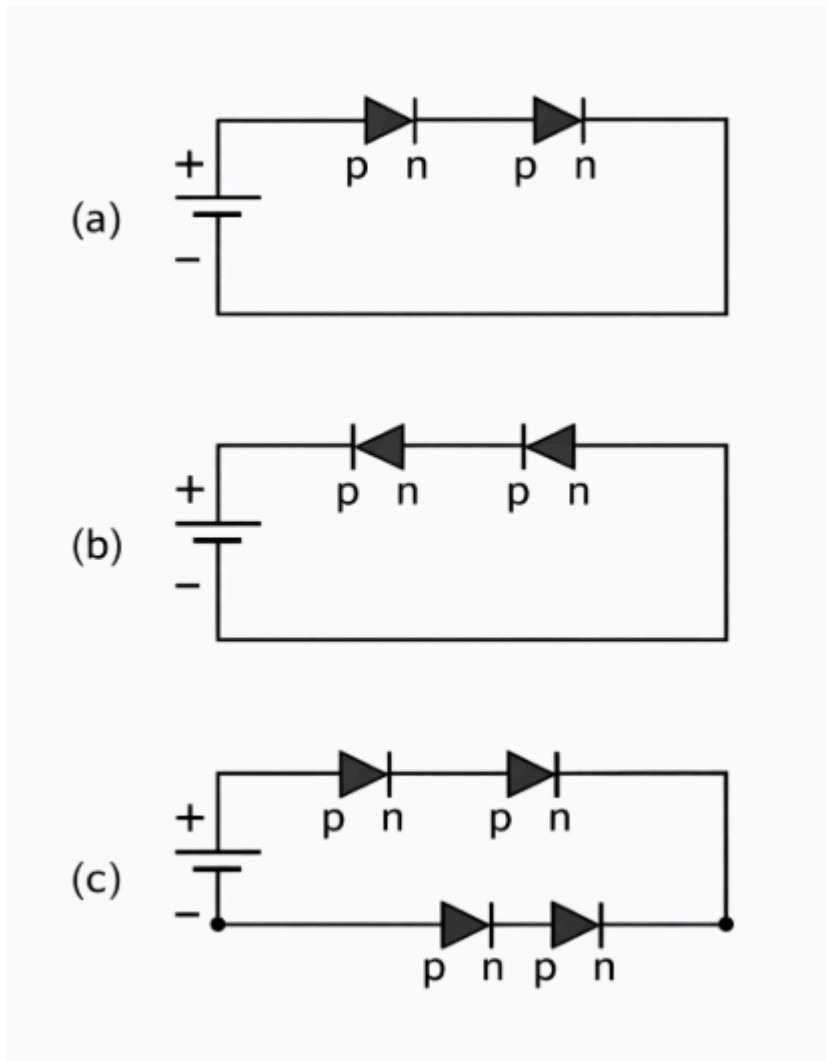

- (1) Circuit a
- (2) Circuit b
- (3) Circuits a and c
- (4) Circuits b and c

**Correct Answer:** (3)

**Explanation:** Identical junctions under same bias polarity have equal potential drop.

**QUESTION 30:** A ray of light is incident at  $60^\circ$  on a surface separating air and a medium of refractive index  $\sqrt{3}$ . The angle between reflected and refracted rays is:

- (1)  $30^\circ$

- (2)  $60^\circ$
- (3)  $90^\circ$
- (4)  $120^\circ$

**Correct Answer:** (3)

**Explanation:** Using Snell law  $\sin 60^\circ = \sqrt{3} \sin r$  gives  $r = 30^\circ$  so angle  $= 180^\circ - 60^\circ - 30^\circ = 90^\circ$ .

## Chemistry

**QUESTION 31:** Number of atoms in 0.5 mole of  $O_2$ :

- (1)  $3.01 \times 10^{23}$
- (2)  $6.02 \times 10^{23}$
- (3)  $1.2 \times 10^{23}$
- (4)  $2.4 \times 10^{23}$

**Correct Answer:** (2)

**Explanation:** 0.5 mol of  $O_2$  contains  $0.5N_A$  molecules, each having 2 atoms  $\rightarrow$  total atoms  $= N_A = 6.02 \times 10^{23}$ .

**QUESTION 32:** Maximum electrons in  $n = 3$  shell:

- (1) 8
- (2) 18
- (3) 32
- (4) 9

**Correct Answer:** (2)

**Explanation:** Maximum electrons in shell  $= 2n^2 = 2(3)^2 = 18$ .

**QUESTION 33:** Atomic radius decreases across period due to:

- (1) shielding increase
- (2) nuclear charge increase
- (3) electron decrease
- (4) neutron decrease

**Correct Answer:** (2)

**Explanation:** Effective nuclear charge increases across period, pulling electrons closer.

**QUESTION 34:** Bond order of  $N_2$ :

- (1) 2
- (2) 3
- (3) 1
- (4) 2.5

**Correct Answer:** (2)

**Explanation:**  $N_2$  has triple bond  $\rightarrow$  bond order = 3.

**QUESTION 35:** Shape of  $NH_3$ :

- (1) trigonal planar

- (2) tetrahedral
- (3) trigonal pyramidal
- (4) linear

Correct Answer: (3)

Explanation: One lone pair on N causes trigonal pyramidal geometry.

**QUESTION 36:** Spontaneous process when:

- (1)  $\Delta G > 0$
- (2)  $\Delta G < 0$
- (3)  $\Delta H > 0$
- (4)  $\Delta S < 0$

Correct Answer: (2)

Explanation: A process is spontaneous when Gibbs free energy decreases.

**QUESTION 37:** Catalyst affects:

- (1) equilibrium constant
- (2) rate only
- (3) enthalpy
- (4) equilibrium position

Correct Answer: (2)

Explanation: Catalyst changes rate of forward and backward reactions equally.

**QUESTION 38:** pH of neutral water at  $25^\circ\text{C}$ :

- (1) 7
- (2) 0
- (3) 14
- (4) 1

Correct Answer: (1)

Explanation: Neutral solution at  $25^\circ\text{C}$  has  $[\text{H}^+] = 10^{-7} \rightarrow \text{pH} = 7$ .

**QUESTION 39:** Oxidation number of N in  $\text{NH}_3$ :

- (1)  $-3$
- (2)  $+3$
- (3)  $0$
- (4)  $-1$

Correct Answer: (1)

Explanation: Hydrogen is  $+1$ , so N becomes  $-3$ .

**QUESTION 40:** At equilibrium  $\Delta G$ :

- (1) positive
- (2) zero
- (3) negative
- (4) infinity

Correct Answer: (2)

Explanation: At equilibrium Gibbs free energy change equals zero.

**QUESTION 41:** Molarity changes with:

- (1) temperature
- (2) pressure
- (3) mass
- (4) moles only

Correct Answer: (1)

Explanation: Volume changes with temperature, so molarity changes.

**QUESTION 42:** A strong oxidising agent has:

- (1) high reduction potential
- (2) low reduction potential
- (3) zero potential
- (4) negative potential

Correct Answer: (1)

Explanation: A higher reduction potential means stronger oxidising ability.

**QUESTION 43:** Unit of first-order rate constant:

- (1)  $s^{-1}$
- (2)  $molL^{-1}$
- (3)  $Lmol^{-1}s^{-1}$
- (4) none

Correct Answer: (1)

Explanation: First order rate constant has time inverse units.

**QUESTION 44:** Highest electronegativity:

- (1) F
- (2) O
- (3) N
- (4) Cl

Correct Answer: (1)

Explanation: Fluorine is the most electronegative element.

**QUESTION 45:** Hybridisation of carbon in methane:

- (1)  $sp$
- (2)  $sp^2$
- (3)  $sp^3$
- (4)  $sp^3d$

Correct Answer: (3)

Explanation: Methane has a tetrahedral geometry  $\rightarrow sp^3$ .

**QUESTION 46:** Chain isomerism is shown by:

- (1) butane

- (2) ethane
- (3) methane
- (4) propane

Correct Answer: (1)

Explanation: Butane has straight and branched forms.

**QUESTION 47:** *SN*1 favored by:

- (1) primary carbocation
- (2) tertiary carbocation
- (3) methyl
- (4) none

Correct Answer: (2)

Explanation: The tertiary carbocation is most stable.

**QUESTION 48:** Phenol is more acidic due to:

- (1) resonance
- (2) hyperconjugation
- (3) steric
- (4) inductive only

Correct Answer: (1)

Explanation: Phenoxide ion is stabilised by resonance.

**QUESTION 49:** Positive Tollens test:

- (1) acetone
- (2) formaldehyde
- (3) ether
- (4) alkene

Correct Answer: (2)

Explanation: Aldehydes give Tollens' test; formaldehyde is an aldehyde.

**QUESTION 50:** Most acidic:

- (1)  $CH_3COOH$
- (2)  $CCl_3COOH$
- (3)  $HCOOH$
- (4)  $C_2H_5COOH$

Correct Answer: (2)

Explanation:  $-I$  effect of Cl increases acidity.

**QUESTION 51:** Most basic in water:

- (1)  $NH_3$
- (2)  $CH_3NH_2$
- (3)  $(CH_3)_2NH$
- (4)  $(CH_3)_3N$

Correct Answer: (3)

Explanation: Secondary amines are strongest in aqueous medium.

**QUESTION 52:** Protein units:

- (1) nucleotides
- (2) amino acids
- (3) glucose
- (4) fatty acids

Correct Answer: (2)

Explanation: Proteins are polymers of amino acids.

**QUESTION 53:** DNA sugar:

- (1) ribose
- (2) deoxyribose
- (3) glucose
- (4) fructose

Correct Answer: (2)

Explanation: DNA contains deoxyribose sugar.

**QUESTION 54:** Coordination number of  $[Co(NH_3)_6]^{3+}$ :

- (1) 4
- (2) 6
- (3) 2
- (4) 8

Correct Answer: (2)

Explanation: Six ligands attached to cobalt.

**QUESTION 55:** Transition elements show:

- (1) variable oxidation states
- (2) fixed valency
- (3) no color
- (4) inertness

Correct Answer: (1)

Explanation: Due to partially filled *d* orbitals.

**QUESTION 56:** Most electronegative halogen:

- (1) F
- (2) Cl
- (3) Br
- (4) I

Correct Answer: (1)

Explanation: Fluorine has the highest electronegativity.

**QUESTION 57:** Ammonia is:

- (1) Lewis acid

- (2) Lewis base
- (3) neutral
- (4) amphoteric

Correct Answer: (2)

Explanation: Lone pair on nitrogen donates electrons.

**QUESTION 58:** General formula of alkene:

- (1)  $C_nH_{2n}$
- (2)  $C_nH_{2n+2}$
- (3)  $C_nH_{2n-2}$
- (4)  $C_nH_n$

Correct Answer: (1)

Explanation: Alkenes contain one double bond.

**QUESTION 59:** Benzene hybridisation:

- (1)  $sp$
- (2)  $sp^2$
- (3)  $sp^3$
- (4) mixed

Correct Answer: (2)

Explanation: Each carbon in benzene is  $sp^2$  hybridised.

**QUESTION 60:** Largest atomic size:

- (1) Na
- (2) Mg
- (3) Al
- (4) Si

Correct Answer: (1)

Explanation: Atomic size decreases across period; Na is the largest.

## Biology

**Question 61:** Which among the following is not a function of mesosome

- (1) Synthesis of food
- (2) Help in cell wall formation
- (3) Help in DNA replication
- (4) Distribution of DNA in daughter cells

**Correct Answer:** (1)

**Explanation:** Mesosomes help in respiration cell wall formation and DNA distribution not food synthesis.

**Question 62:** Which of the following is considered as pacemaker of human heart

- (1) SA node
- (2) AV node

(3) Purkinje fibres

(4) Bundle of His

**Correct Answer:** (1)

**Explanation:** SA node initiates rhythmic contraction of heart.

**Question 63:** Regarding to features of double helix structure of DNA which of the following is wrong

(1) Two polynucleotide chains have antiparallel polarity

(2) The bases in two strands are paired through phosphodiester bonds

(3) Adenine form two hydrogen bonds with thymine

(4) The pitch of the helix is 3.4 nm

**Correct Answer:** (2)

**Explanation:** Bases pair through hydrogen bonds not phosphodiester bonds.

**Question 64:** Formation of different kind of biomes depends on

(1) Light

(2) Temperature

(3) Precipitation

(4) Both 2 and 3

**Correct Answer:** (4)

**Explanation:** Temperature and precipitation determine biome distribution.

**Question 65:** Which of the following bacteria was associated with discovery of penicillin

(1) Streptococcus

(2) Staphylococcus

(3) Saccharomyces cerevisiae

(4) Propionobacterium

**Correct Answer:** (2)

**Explanation:** Penicillin inhibits Staphylococcus studied in discovery.

**Question 66:** Fluidity of plasma membrane is due to

(1) Lipids

(2) Proteins

(3) Carbohydrates

(4) Cholesterol

**Correct Answer:** (1)

**Explanation:** Lipid bilayer provides fluid nature to membrane.

**Question 67:** Population ecology is an important area of ecology because it links ecology with

(1) Population genetics

- (2) Evolution
- (3) Physiognomy
- (4) Both 1 and 2

**Correct Answer:** (4)

**Explanation:** Population ecology connects genetics and evolution.

**Question 68:** Phosphoric acid remain associated with which carbon of sugar in nucleotide

- (1) 1st
- (2) 3rd
- (3) 4th
- (4) 5th

**Correct Answer:** (4)

**Explanation:** Phosphate group attaches to 5' carbon.

**Question 69:** Which of the following can be used for cultivation of SCP

- (1) Waste water from potato processing plants
- (2) Straw
- (3) Sewage
- (4) All above

**Correct Answer:** (4)

**Explanation:** All are substrates for SCP production.

**Question 70:** Temperature is the most ecologically relevant environmental factor. In which habitat temperature can exceed 100°C

- (1) Tropical desert
- (2) Thermal springs
- (3) Deep sea hydrothermal vents
- (4) Both 2 and 3

**Correct Answer:** (4)

**Explanation:** Hydrothermal vents and thermal springs exceed 100°C.

**Question 71:** Which of the following is the most abundant protein in the biosphere

- (1) RuBisCO
- (2) Pepsin
- (3) Actin
- (4) Myosin

**Correct Answer:** (1)

**Explanation:** RuBisCO is the most abundant enzyme involved in carbon fixation.

**Question 72:** Which of the following is a C<sub>4</sub> plant

- (1) Wheat
- (2) Rice

(3) Maize

(4) Barley

**Correct Answer:** (3)

**Explanation:** Maize performs  $C_4$  photosynthesis with Kranz anatomy.

**Question 73:** Which part of nephron is impermeable to water

(1) Proximal convoluted tubule

(2) Descending limb of Henle

(3) Ascending limb of Henle

(4) Collecting duct

**Correct Answer:** (3)

**Explanation:** Ascending limb actively transports ions but is impermeable to water.

**Question 74:** Which of the following hormone regulates metamorphosis in frog

(1) Thyroxine

(2) Insulin

(3) Adrenaline

(4) Cortisol

**Correct Answer:** (1)

**Explanation:** Thyroxine controls amphibian metamorphosis.

**Question 75:** The enzyme responsible for transcription is

(1) DNA polymerase

(2) RNA polymerase

(3) Ligase

(4) Helicase

**Correct Answer:** (2)

**Explanation:** RNA polymerase synthesizes RNA during transcription.

**Question 76:** Which of the following is not a component of nucleotide

(1) Nitrogenous base

(2) Pentose sugar

(3) Phosphate group

(4) Fatty acid

**Correct Answer:** (4)

**Explanation:** Nucleotide contains base sugar and phosphate only.

**Question 77:** Exponential growth phase is represented by

(1) J shaped curve

(2) S shaped curve

(3) Bell shaped curve

(4) Straight line

**Correct Answer:** (1)

**Explanation:** Exponential growth produces J shaped curve.

**Question 78:** Which of the following is a secondary lymphoid organ

(1) Bone marrow

(2) Thymus

(3) Spleen

(4) Liver

**Correct Answer:** (3)

**Explanation:** Spleen is secondary lymphoid organ for immune response.

**Question 79:** Which of the following is used as selectable marker in cloning vectors

(1) Ampicillin resistance gene

(2) rRNA gene

(3) tRNA gene

(4) Histone gene

**Correct Answer:** (1)

**Explanation:** Antibiotic resistance genes act as selectable markers.

**Question 80:** Which of the following is an example of mutualism

(1) Tapeworm and human

(2) Lichen

(3) Predator and prey

(4) Amensalism

**Correct Answer:** (2)

**Explanation:** Lichen shows mutualistic association of algae and fungi.

**Question 81:** Which of the following pigment is present in reaction centre of Photosystem II

(1)  $P_{680}$

(2)  $P_{700}$

(3) Cytochrome

(4) Xanthophyll

**Correct Answer:** (1)

**Explanation:** Photosystem II reaction centre chlorophyll is  $P_{680}$ .

**Question 82:** Which of the following is responsible for maintaining membrane potential in neurons

(1)  $Na^+ K^+$  pump

(2)  $Ca^{2+}$  pump

(3)  $H^+$  pump

(4)  $Cl^-$  pump

**Correct Answer:** (1)

**Explanation:**  $\text{Na}^+ \text{K}^+$  ATPase maintains resting membrane potential.

**Question 83:** In Hardy Weinberg equation  $p^2 + 2pq + q^2 = 1$  value of  $2pq$  represents

- (1) Homozygous dominant
- (2) Homozygous recessive
- (3) Heterozygous genotype
- (4) Allele frequency

**Correct Answer:** (3)

**Explanation:**  $2pq$  represents heterozygous individuals.

**Question 84:** Which of the following is produced during anaerobic respiration in yeast

- (1) Lactic acid
- (2) Ethanol
- (3) Pyruvate
- (4) Acetyl CoA

**Correct Answer:** (2)

**Explanation:** Yeast fermentation produces ethanol and  $\text{CO}_2$ .

**Question 85:** The first stable product of  $\text{C}_3$  cycle is

- (1) Oxaloacetic acid
- (2) Phosphoglyceric acid
- (3) Pyruvic acid
- (4) Malic acid

**Correct Answer:** (2)

**Explanation:** First stable product is 3-phosphoglycerate.

**Question 86:** Which of the following is an autoimmune disease

- (1) AIDS
- (2) Rheumatoid arthritis
- (3) Tuberculosis
- (4) Typhoid

**Correct Answer:** (2)

**Explanation:** Rheumatoid arthritis involves immune attack on joints.

**Question 87:** Restriction enzymes belong to class of

- (1) Ligases
- (2) Nucleases
- (3) Polymerases
- (4) Isomerases

**Correct Answer:** (2)

**Explanation:** Restriction enzymes cut DNA so they are nucleases.

**Question 88:** Which of the following is not a greenhouse gas

- (1) CO<sub>2</sub>
- (2) CH<sub>4</sub>
- (3) O<sub>2</sub>
- (4) N<sub>2</sub>O

**Correct Answer:** (3)

**Explanation:** Oxygen does not absorb infrared radiation.

**Question 89:** During muscle contraction calcium ions bind with

- (1) Actin
- (2) Troponin
- (3) Myosin
- (4) Tropomyosin

**Correct Answer:** (2)

**Explanation:** Ca<sup>2+</sup> binds troponin exposing binding sites.

**Question 90:** Which of the following is a living fossil

- (1) Peripatus
- (2) Limulus
- (3) Archaeopteryx
- (4) Both 1 and 2

**Correct Answer:** (4)

**Explanation:** Peripatus and Limulus are considered living fossils.

**Question 91:** Which of the following is the functional unit of kidney

- (1) Neuron
- (2) Nephron
- (3) Alveoli
- (4) Glomerulus

**Correct Answer:** (2)

**Explanation:** Nephron is structural and functional unit of kidney.

**Question 92:** The enzyme that joins DNA fragments during replication is

- (1) Helicase
- (2) Ligase
- (3) Primase
- (4) Topoisomerase

**Correct Answer:** (2)

**Explanation:** DNA ligase joins Okazaki fragments.

**Question 93:** Which of the following is example of commensalism

- (1) Orchid on mango tree
- (2) Lichen
- (3) Tapeworm in intestine
- (4) Predator prey

**Correct Answer:** (1)

**Explanation:** Orchid benefits while tree unaffected.

**Question 94:** Which of the following is a disaccharide

- (1) Glucose
- (2) Fructose
- (3) Sucrose
- (4) Ribose

**Correct Answer:** (3)

**Explanation:** Sucrose is composed of glucose and fructose.

**Question 95:** The site of fertilization in human female is

- (1) Uterus
- (2) Cervix
- (3) Ampulla of fallopian tube
- (4) Ovary

**Correct Answer:** (3)

**Explanation:** Fertilization occurs in ampullary region.

**Question 96:** Which of the following is a pyrimidine base

- (1) Adenine
- (2) Guanine
- (3) Cytosine
- (4) Both 1 and 2

**Correct Answer:** (3)

**Explanation:** Cytosine is pyrimidine base.

**Question 97:** Logistic growth curve is

- (1) J shaped
- (2) S shaped
- (3) Linear
- (4) Circular

**Correct Answer:** (2)

**Explanation:** Logistic growth produces sigmoid curve.

**Question 98:** Which of the following is hormone secreted by posterior pituitary

- (1) GH
- (2) TSH
- (3) ADH
- (4) ACTH

**Correct Answer:** (3)

**Explanation:** Posterior pituitary releases ADH and oxytocin.

**Question 99:** Bt cotton is resistant to

- (1) Fungi
- (2) Bacteria
- (3) Insects
- (4) Virus

**Correct Answer:** (3)

**Explanation:** Bt toxin protects against insect pests.

**Question 100:** Which of the following is not a micronutrient for plants

- (1) Iron
- (2) Zinc
- (3) Nitrogen
- (4) Copper

**Correct Answer:** (3)

**Explanation:** Nitrogen is macronutrient.

Motion